

8 7 6 5 4 3 2 1

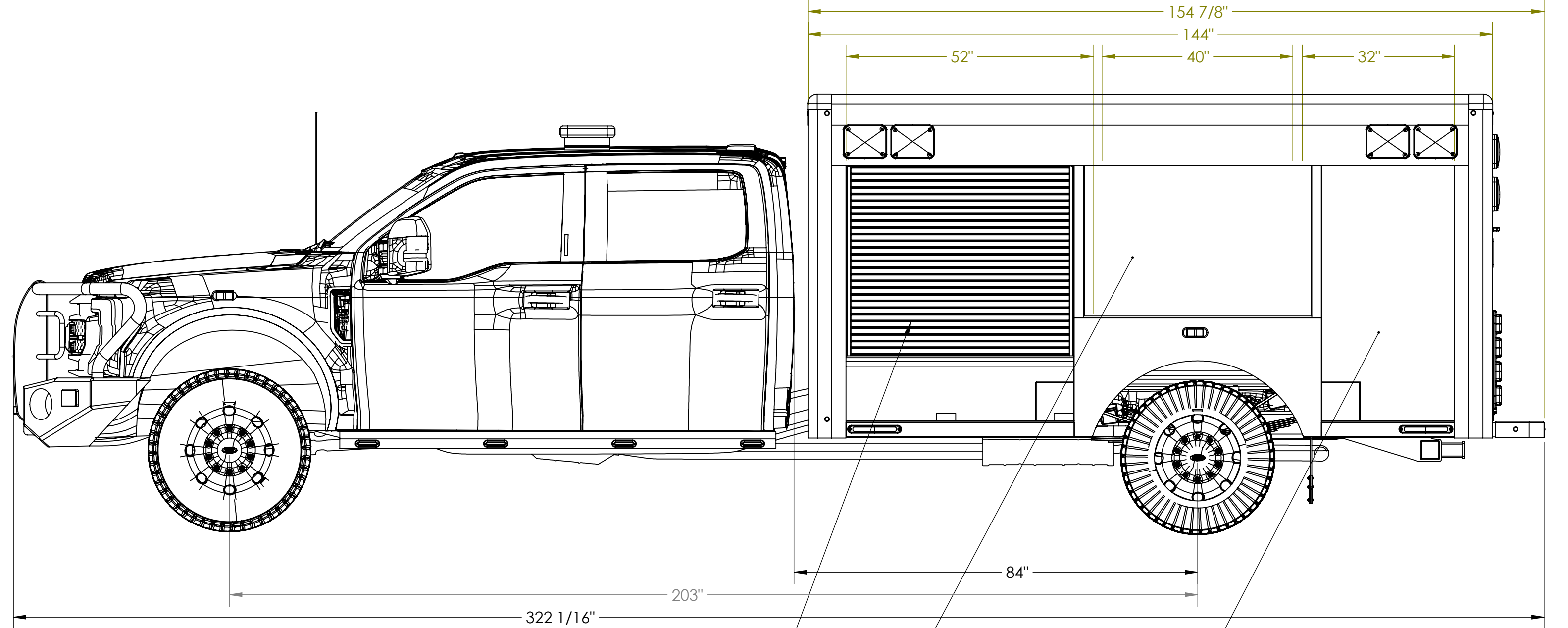
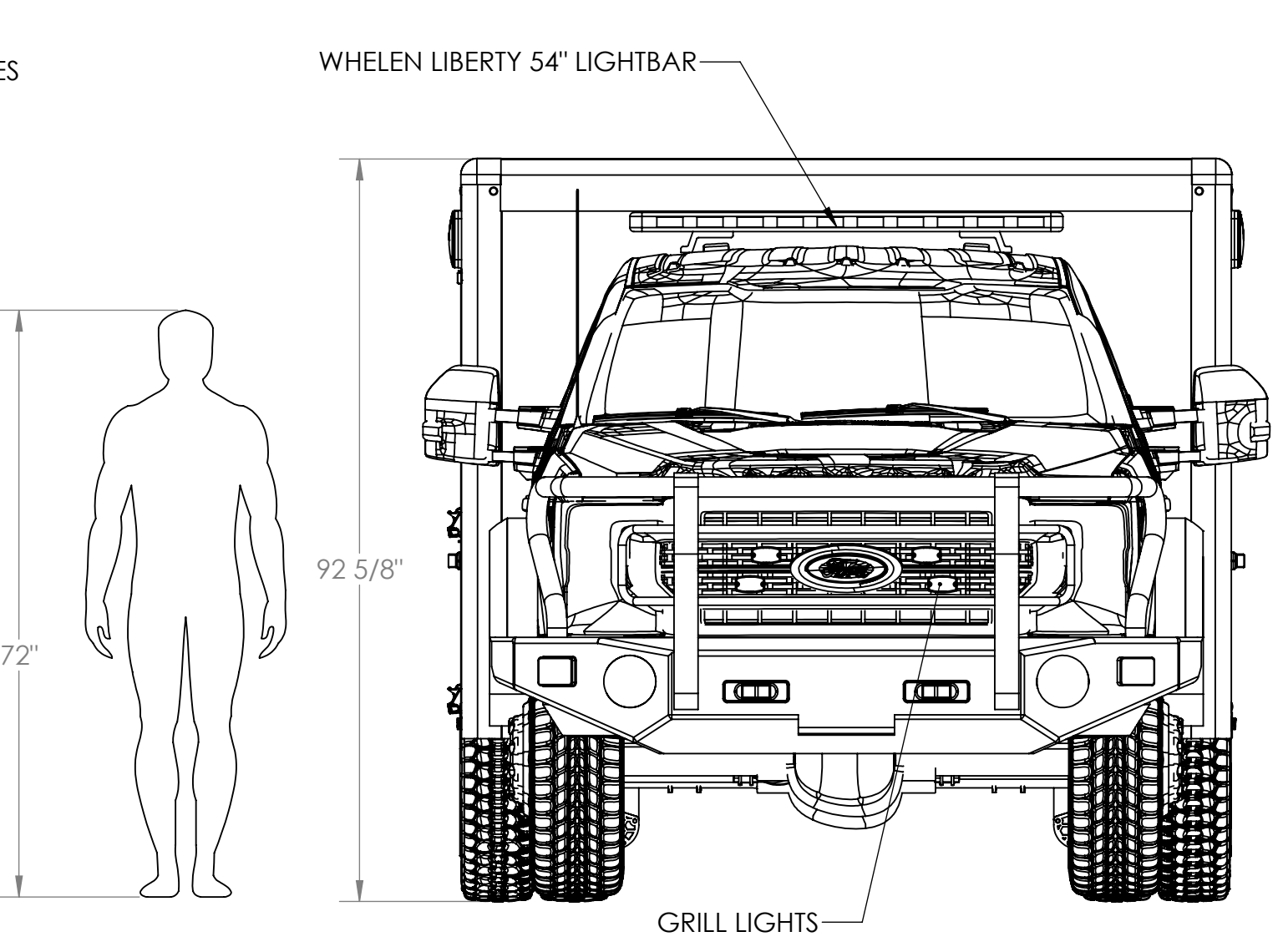
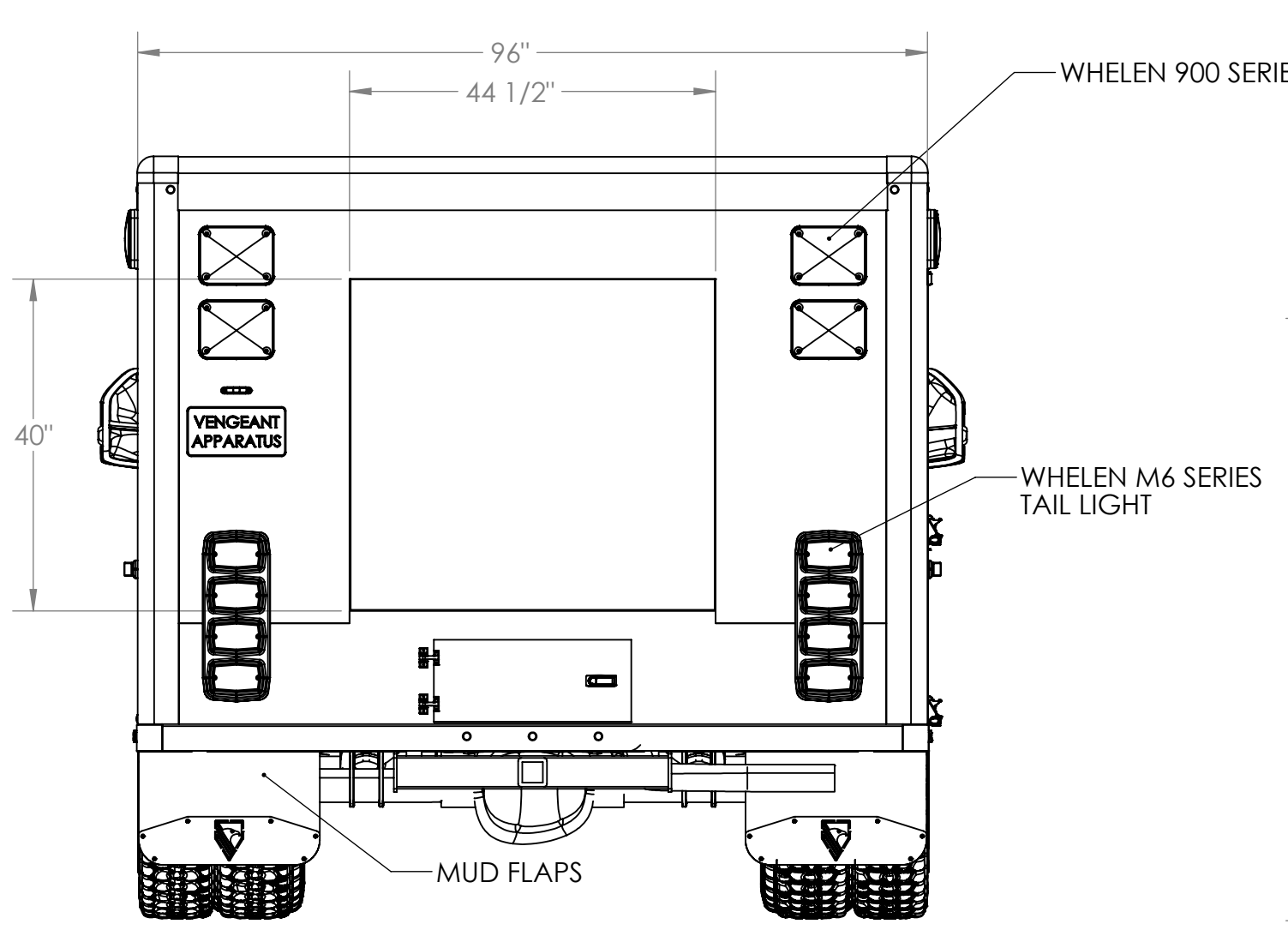
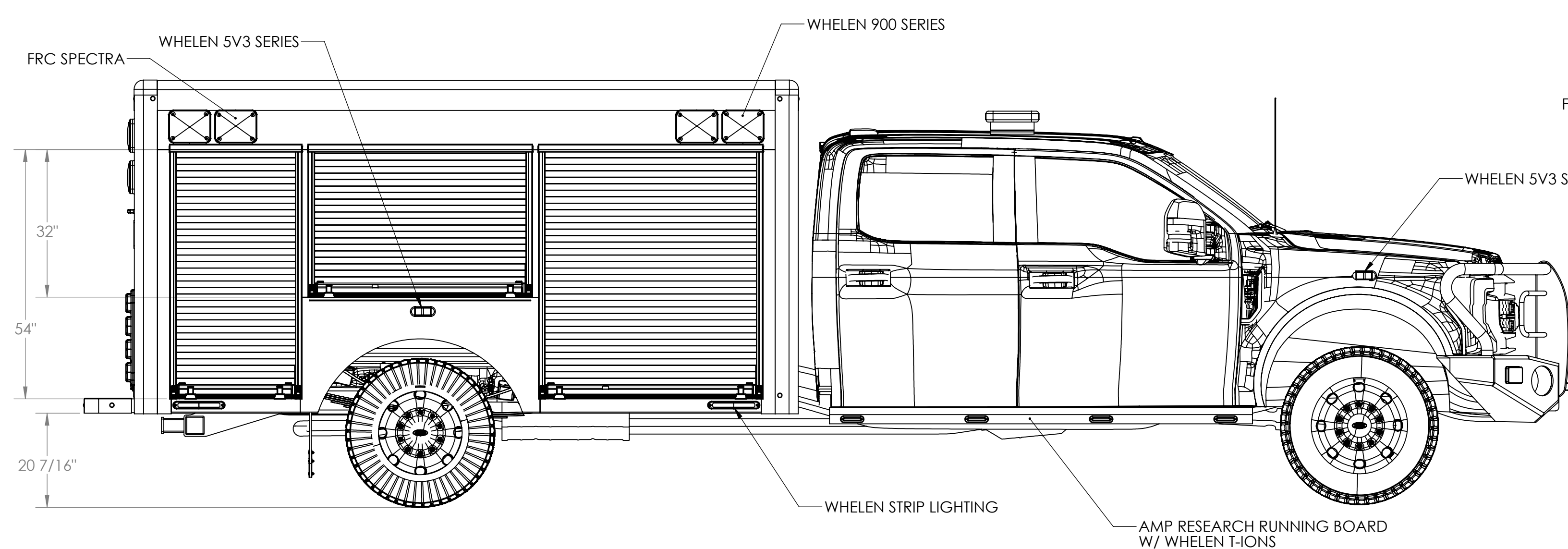

SS-1/CS-1 : 48" W x 54" L x XVERSE COMPARTMENT W/ ROLL UP DOOR AND LOWER ELECTRICAL COMPARTMENT

SS-2/CS-2 : 48" W x 32" L x 23" DEEP COMPARTMENT W/ ROLL UP DOOR

SS-3/CS-3 : 28" W x 54" L x 23" DEEP COMPARTMENT W/ ROLL UP DOOR

R-1 : 44 1/2" W x 40" L x 86" DEEP REAR COMPARTMENT W/ ROLL UP DOOR

FOR REFERENCE PURPOSES ONLY
 ANY DISCREPANCIES BETWEEN DRAWING AND SPEC, REFER TO SPEC
 DIMENSIONS SUBJECT TO CHANGE IF A DESIGN CHANGE IS MADE

REV		CHANGE	NAME	DATE	MATERIAL	VENGEANT APPARATUS	
		REVISIONS				DESCRIPTION	
						NEW KINGSTOWN	
						SPECIFICATION SHEET	
						SIZE DWG. NO. REV	
						D NEW KINGSTOWN	
						SCALE: 1:20 WEIGHT: SHEET 1 OF 1	

8 7 6 5 4 3 2 1