

- HOSEBED CAPACITIES
- ① 300' OF 2.00" MERCEDES AQUAFLOW HOSE
 - ② 500' OF 3.00" MERCEDES AQUAFLOW HOSE
 - ③ 1500' OF 4.00" MERCEDES MEGAFLOW HOSE
 - ④ 300' OF 1.50" MERCEDES AQUAFLOW HOSE
 - ⑤ 300' OF 2.00" MERCEDES AQUAFLOW HOSE

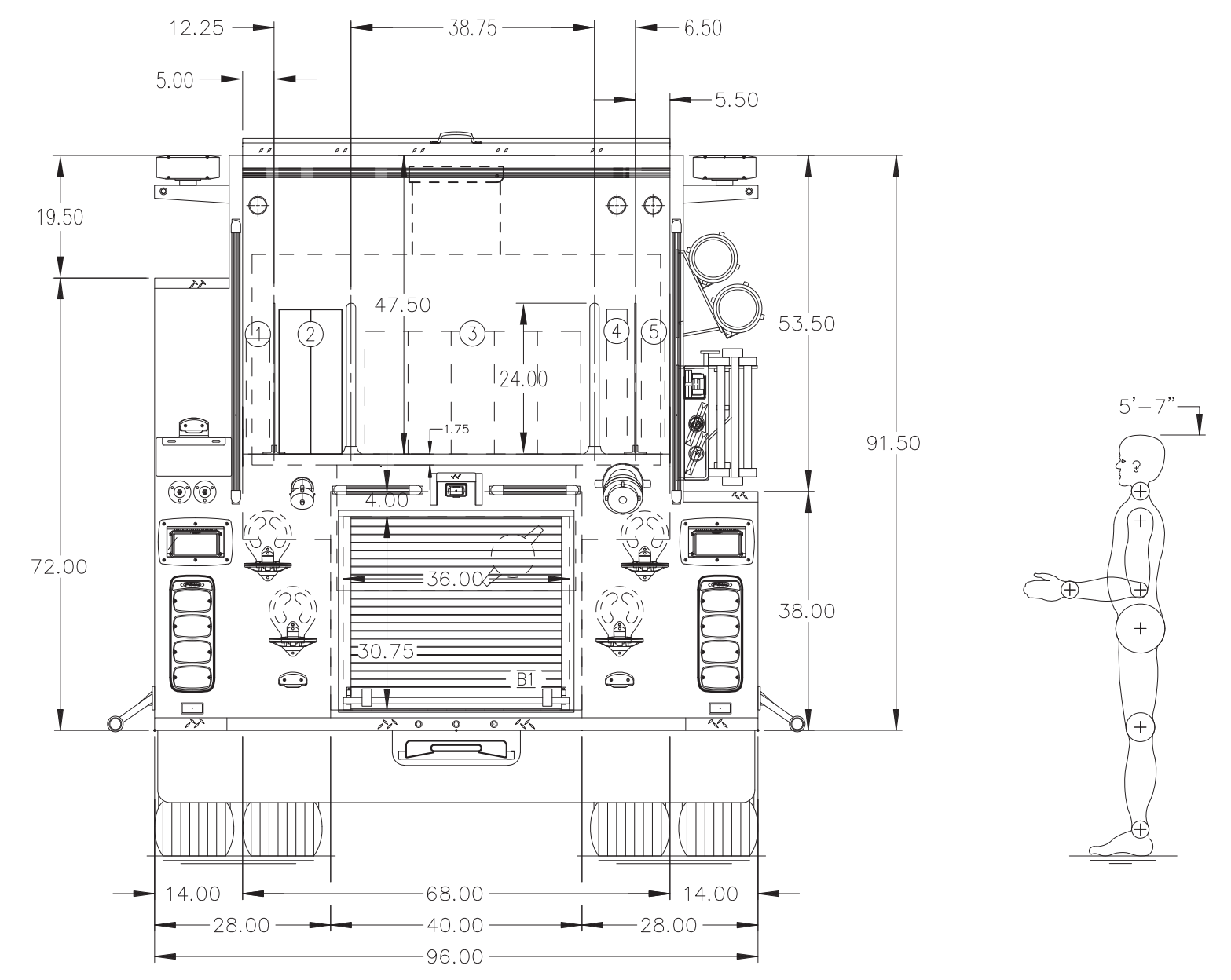
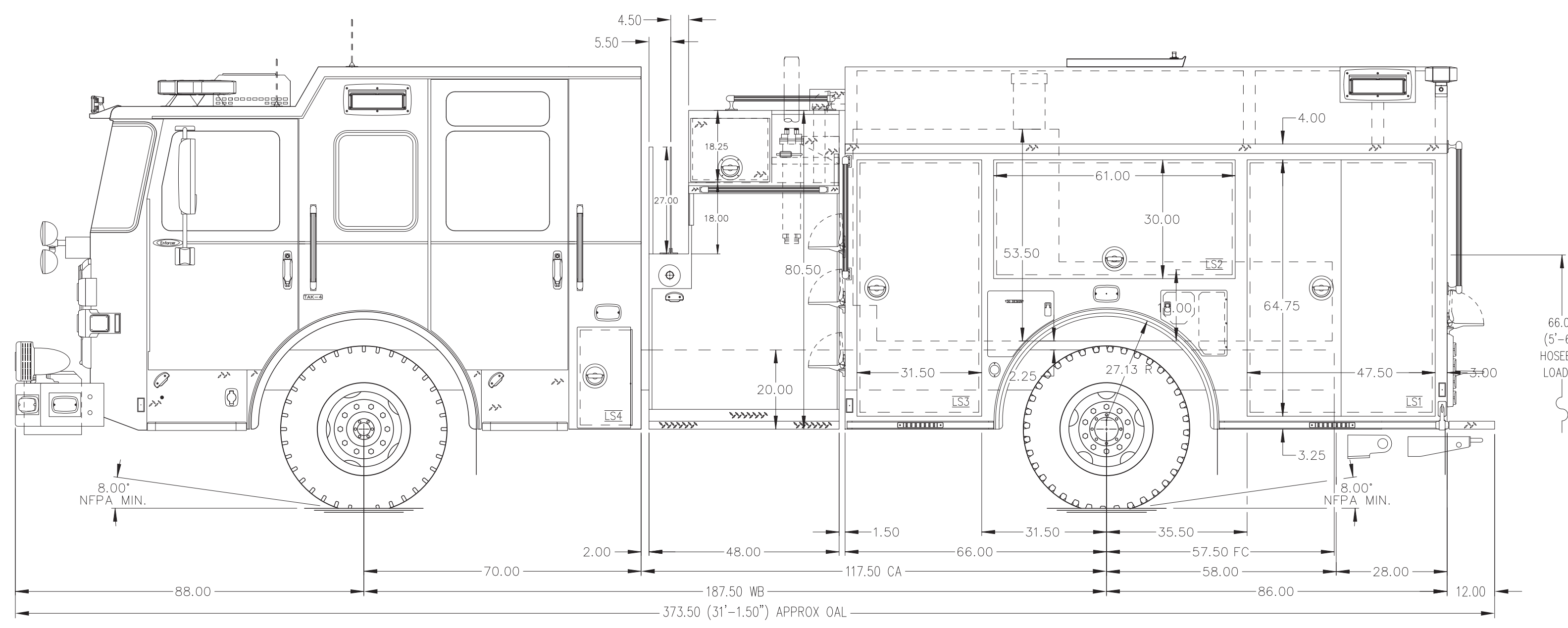

ALUMINUM BODY MAX O.A.L. 378.00" MAX O.A.H. 120.00" SIDE ROLL AND FRONTAL IMPACT PROTECTION

NOTE
DIMENSIONS SHOWN ARE APPROXIMATE AND ARE SUBJECT TO MINOR DEVIATIONS AS MAY OCCUR OR BE NECESSARY IN CONSTRUCTION. MINOR DETAILS NOT SHOWN.

REV	DATE	BY	CH	ENFORCER

	TITLE	1500-D-750P, 152" PUMPER BODY, FDLER (2) CROSSLAYS, DELUGE, RS LADDER BRACKETS	PROPOSAL	803	
	MAKE	PIERCE	SCALE	DATE	
	MODEL		DRAWN BY	KRG	
	DWG NO.	PRELIMINARY PRINT ONLY	CHECKED BY	N/A	
			SHEET SIZE	D	
FOR	FRANKLIN FIRE COMPANY CHAMBERSBURG, PA	CHECKED BY	N/A	SHEET NO.	1 OF 1