

- HOSEBED CAPACITIES**
- ① 200' OF 1.75" SINGLE STACK MERCEDES
 - ② 200' OF 2.50" MERCEDES
 - ③ 400' OF 3.00" MERCEDES
 - ④ 1000' OF 5.00" SNAP TIE RUBBER
 - ⑤ 300' OF 1.75" SINGLE STACK MERCEDES
 - ⑥ 200' OF 1.75" SINGLE STACK MERCEDES

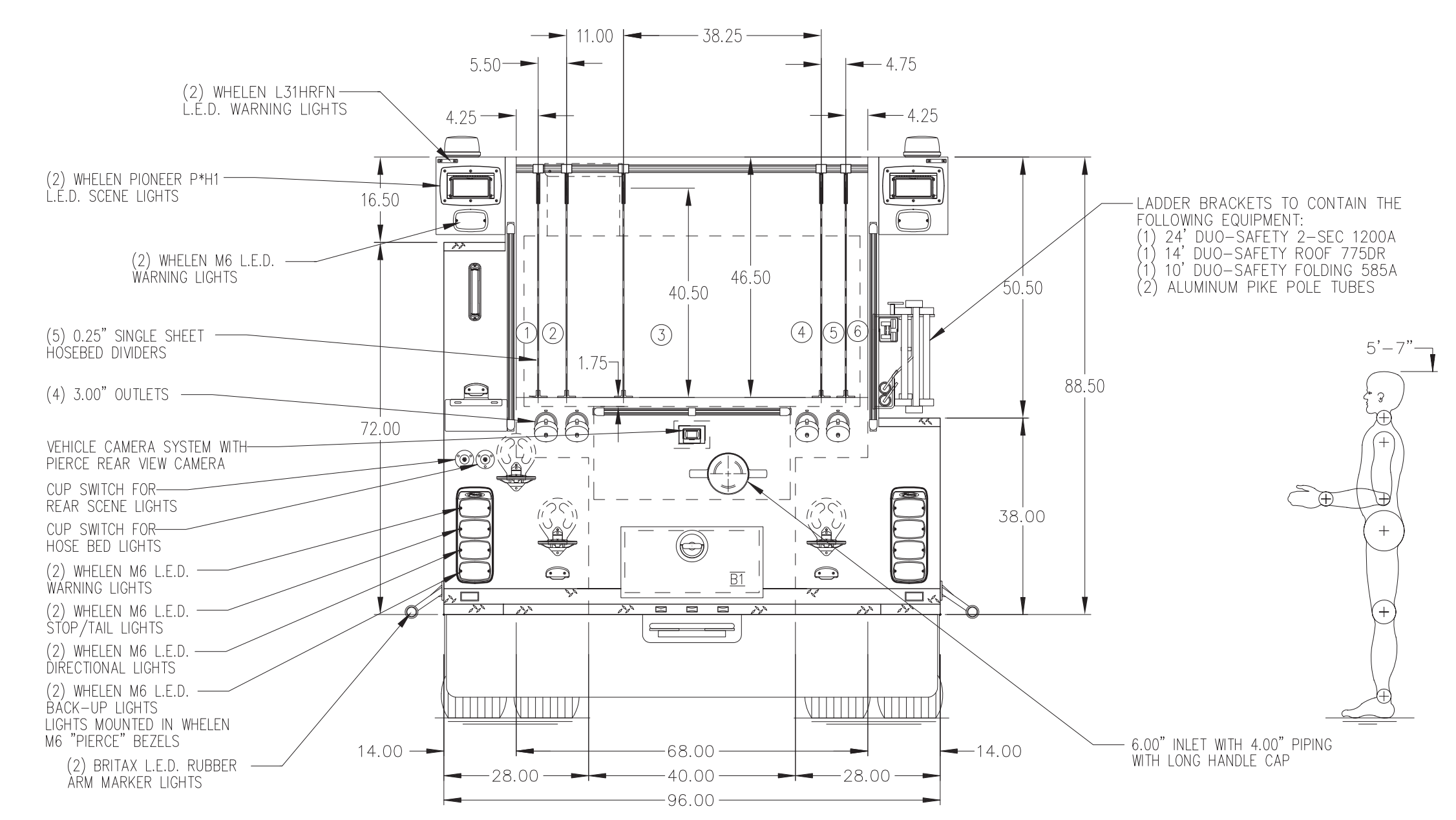
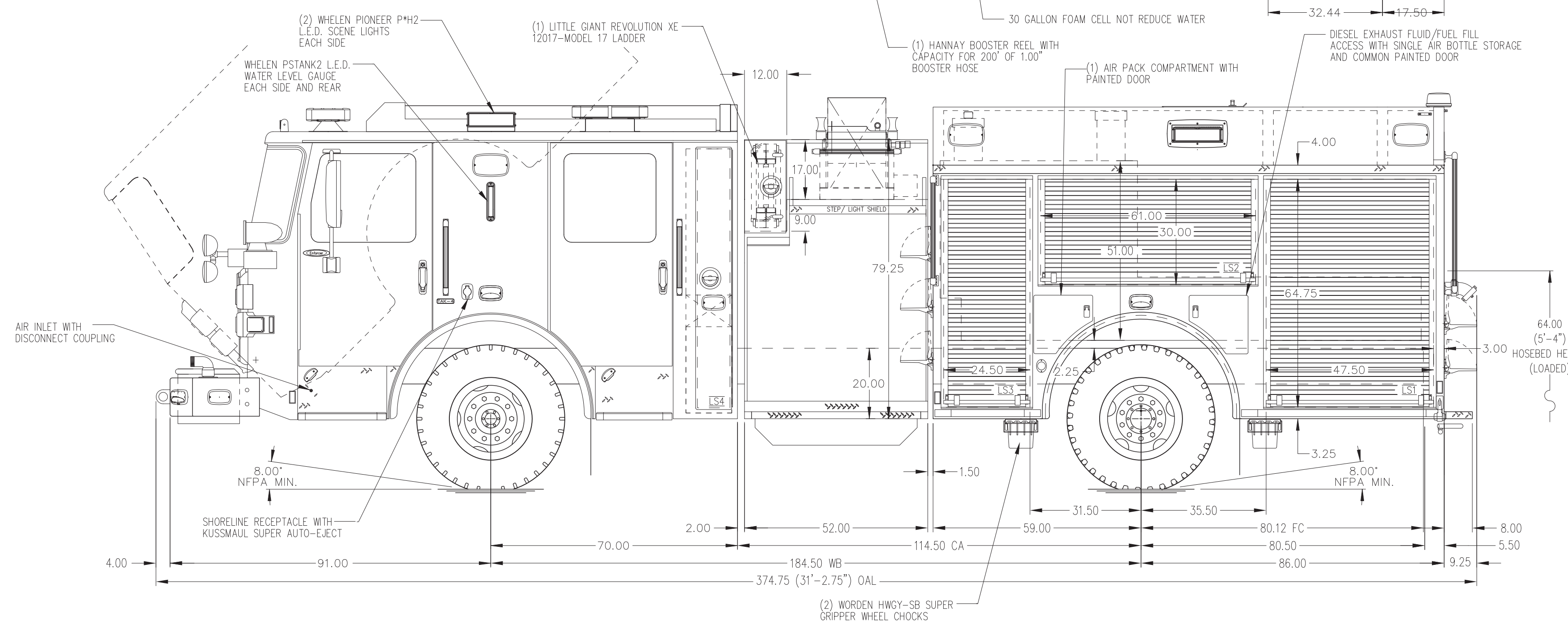

ALUMINUM BODY

SIDE ROLL AND FRONTAL IMPACT PROTECTION

NOTE
DIMENSIONS SHOWN ARE APPROXIMATE AND ARE SUBJECT TO MINOR DEVIATIONS AS MAY OCCUR OR BE NECESSARY IN CONSTRUCTION. MINOR DETAILS NOT SHOWN.

PIERCE MANUFACTURING INC.		PROPOSAL	794
		SCALE	DATE
TITLE	1750-D-780P, 750 WATER, 30 FOAM, 145" FHDS, LOW PS, FDLER LADDERS ON SIDE, BOOSTER REEL	DRAWN BY	KRG
FOR	BOYERTOWN AREA FIRE AND RESCUE BOYERTOWN, PENNSYLVANIA	CHECKED BY	N/A
DWG NO.	PRELIMINARY PRINT ONLY	SHEET SIZE	SHEET NO.
REV	DATE	BY	CH

01SEP22	KRG	-	CHASSIS DATA
22JUN22	KRG	-	MAKE
08APR22	KRG	-	MODEL
REV	DATE	BY	CH ENFORCER