

- HOSEBED CAPACITIES
- ① 200' OF 3.00" SINGLE STACK
 - ② 300' OF 2.50" DOUBLE STACK
 - ③ 1200' OF 4.00" LDH
 - ④ 200' OF 2.50" SINGLE STACK
 - ⑤ 250' OF 1.75" SINGLE STACK

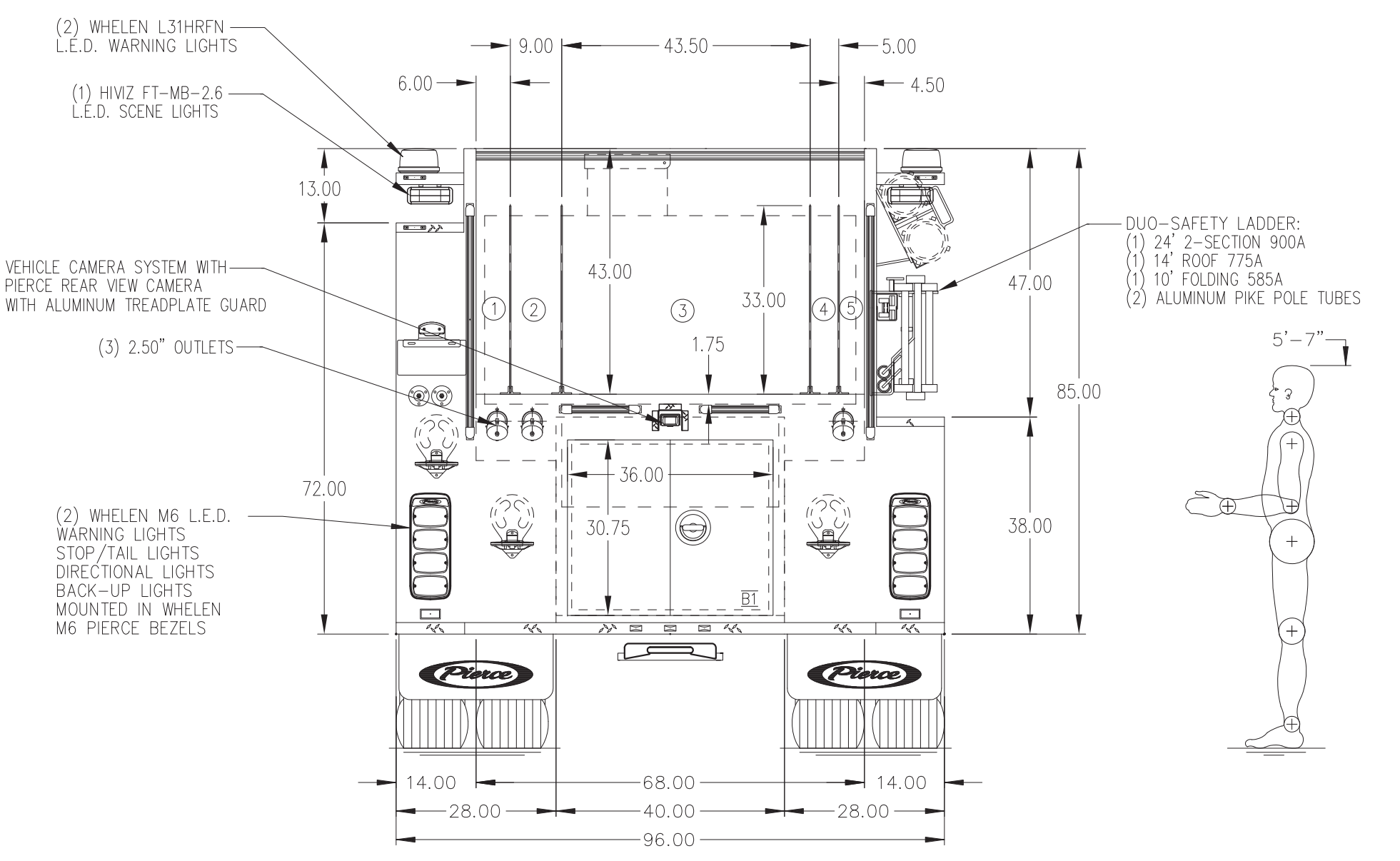

ALUMINUM BODY

NOTE
DIMENSIONS SHOWN ARE APPROXIMATE AND ARE SUBJECT TO MINOR DEVIATIONS AS MAY OCCUR OR BE NECESSARY IN CONSTRUCTION. MINOR DETAILS NOT SHOWN.

		PROPOSAL	772
		SCALE	DATE
TITLE 1500-D-1000G WATER TANK, 161" LS FDLER/RS LOW BODY LADDER BRACKETS RS, (2) CROSSLAYS		DRAWN BY	KRG
FOR MT. PLEASANT TOWNSHIP VOLUNTEER FIRE COMPANY HICKORY, PA		CHECKED BY	N/A
DWG NO. PRELIMINARY PRINT ONLY		SHEET SIZE	SHEET NO.
		D	1 OF 1

REV	DATE	BY	CH	SABER FR
▽	26APR23	KRG	-	CHASSIS DATA
▽	09MAR23	KRG	-	MAKE
▽	09MAR23	KRG	-	PIERCE
▽	09MAR23	KRG	-	MODEL