

- HOSEBED CAPACITIES**
- ① - 200' OF 1.75\"/>

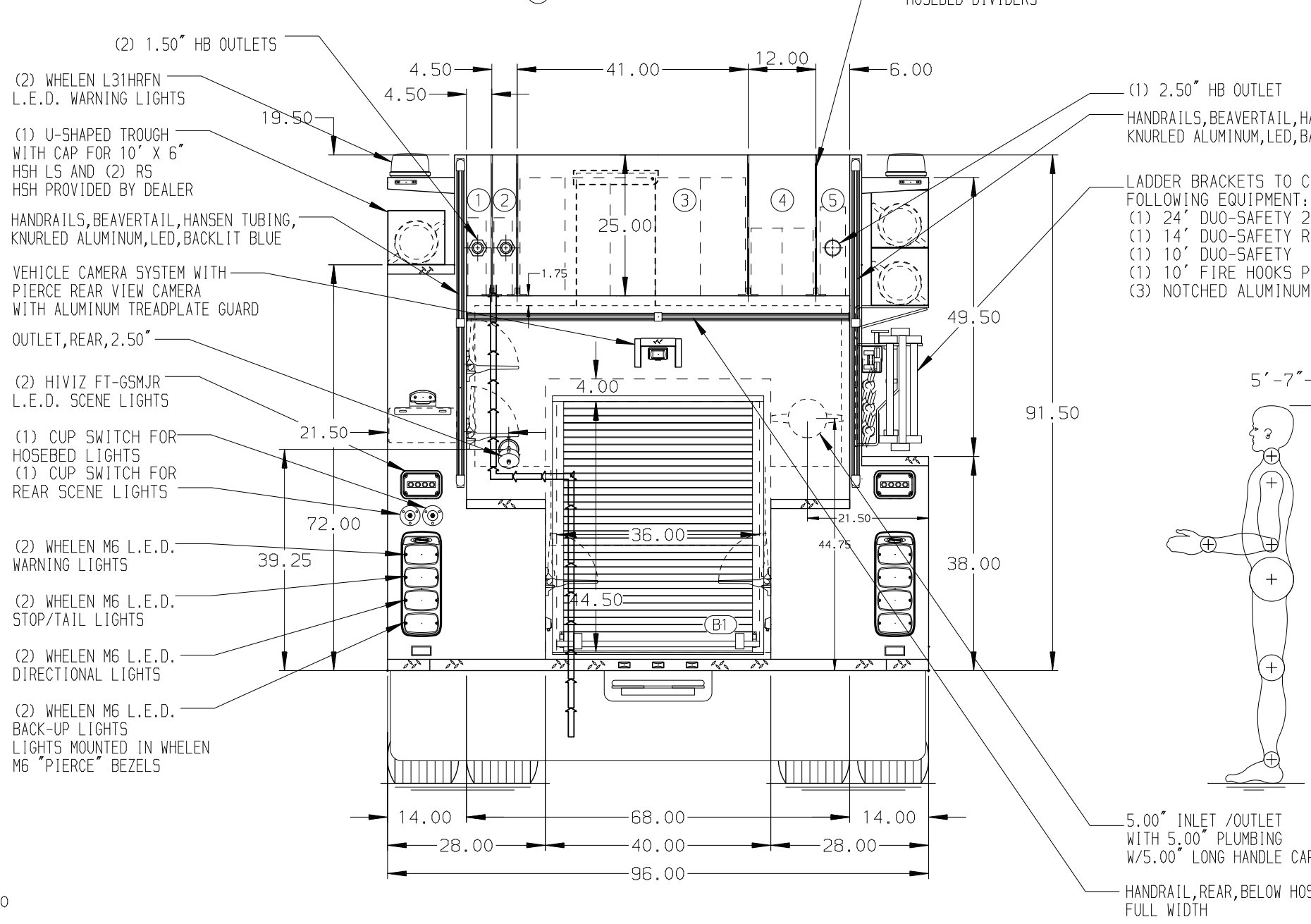

**ALUMINUM BODY**

**NOTE**  
DIMENSIONS SHOWN ARE APPROXIMATE AND ARE SUBJECT TO MINOR DEVIATIONS AS MAY OCCUR OR BE NECESSARY IN CONSTRUCTION. MINOR DETAILS NOT SHOWN.

REV	DATE	BY	CH	SABER FR
03MAY22	RHU	GSC		CHASSIS DATA
06APR22	RHU	GSC		MAKE
16MAR22	RHU	GSC		PIERCE
27JAN22	CDU	CDU		MODEL

		JOB NO.	37268
		SCALE	DATE
<b>TITLE</b> 2000-D-1000 GALLON WATER TANK, 161\"/>	<b>FOR</b> GLENN LEBANON FIRE COMPANY LEBANON, PENNSYLVANIA	DRAWN BY	JUS 18JAN22
		CHECKED BY	CDU 20JAN22
<b>DWG NO.</b> 37268AD		SHEET SIZE	SHEET NO.
		D	1 OF 1